

Spark Gap Tesla Coil DIY Kit

1.Introduction:

It is a Spark Gap Tesla Coil DIY Kit. The Tesla coil can produce high temperature and high pressure plasma which can wireless transmission and light fluorescent lamp. It has a wonderful arc. It is a very interesting small production of scientific experiments. This is DIY Tesla coil Kit parts which needs to be soldered and assembled by yourself.

2.Feature:

- 1>.Brilliant arc
- 2>.Wireless transmission
- 3>.Lighting in the air
- 4>.10cm arc

3.Parameter:

- 1>.Product Name:Spark Gap Tesla Coil DIY Kit
- 2>.Work Voltage:DC 12V~36V
- 3>.Work Power:60W-80W
- 4>.Arc length:about 10cm
- 5>.Work Temperature:-40℃~85℃
- 6>.Work Humidity:5%~95%RH
- 7>.Size(Installed):150*150*410mm

4.Component Listing:

NO.	Component Name	PCB Marker	Parameter	QTY
1	Metal Film Resistor	R2,R3	10Kohm 1W	2
2	Metal Film Resistor	R4,R5	470ohm 2W	2
3	Metal Film Resistor		1Mohm 1/4W	11
4	Zener Diode	D1,D2	12V DO-41	2
5	Fast Recovery Diode	D3,D4	1000V 1A DO-41	2
6	IRFP250 MOS FET	Q1,Q2	TO-247	2
7	Sheet metal			2
8	Coil Inductor	L1	100uH	1
9	Spacer			2
10	Screw		M3*12mm	4
11	Nut		M3	2
12	Mut Cap		M3	2
13	PCB		77*73*1.6mm	1
14	Heat sink			2
15	HB950 Terminal	J1	2Pin	1
16	HB950 Terminal	J2	3Pin	1
17	Resonant Capacitor	C1,C2	0.3uF~0.45uF	12
18	Transformer			1
19	1.0mm Enameled Copper Wire		50cm	1

20	1.0mm Enameled Copper Wire		100cm	1
21	Universal board		50*70*1.2mm	1
22	Secondary Coil		D40*H247mm	1
23	Stainless Steel Metal Ball		D6mm	1
24	Round Wooden Column		10*10*100mm	4
25	Wooden Board		150*150*3mm	2
26	Primary Coil Plastic Bracket		D82*H70mm	1

5.Application:

- 1>.Training welding skills
- 2>.Student school
- 3>.DIY production
- 4>.Project Design
- 5>.Electronic competition
- 6>.Graduation design



6.Note:

- 1>.There is no direct contact between the primary coil and the secondary coil.
- 2>.The secondary coil must be connected to ground before power ON.
- 3>.Please do not touch the product with your hands when working.
- 4>.Please provide sufficient and stable power supply. It is recommended to use 19V4.7A power supply.

7.Installation Tips:

- 1>.User needs to prepare the welding tool and hot melt adhesive at first.
 - 1.1>.Soldering iron (<50 Watt)
 - 1.2>.Rosin core ("radio") solder
 - 1.3>.Wire cutters
 - 1.4>.Wire strippers
 - 1.5>.Philips screwdriver
 - 1.6>.DC 12V~36V power adapter
 - 1.7>.Hot melt adhesive
 - 1.8>.Insulating tape
 - 1.9>.More than 30cm wire(used in Step-46)
- 2>.Please be patient until the installation is complete.
- 3>.The package is DIY kit.It need finish install by user.
- 4>.The soldering iron can't touch the components for a long time(1.0 second), otherwise it will damage the components.
- 5>.Pay attention to the positive and negative of the components.
- 6>.Strictly prohibit short circuit.
- 7>.Install complex components preferentially.
- 8>.Make sure all components are in right direction and right place.
- 9>.It is strongly recommended to read the installation manual before starting installation!!!
- 10>.Please wear anti-static gloves or anti-static wristbands when installing electronic components.

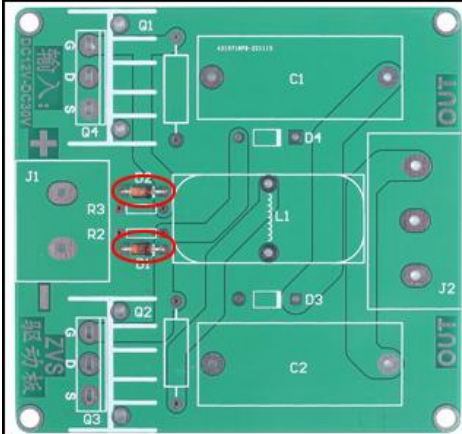
8. Installation Steps(Please be patient install!!!):

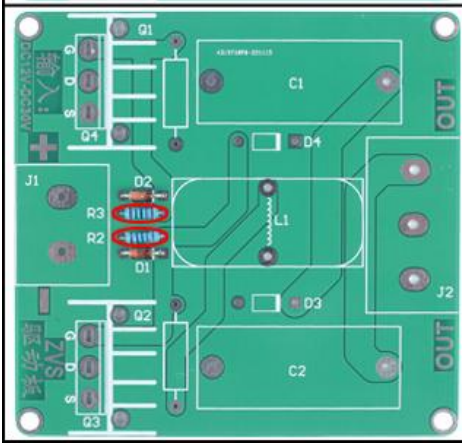
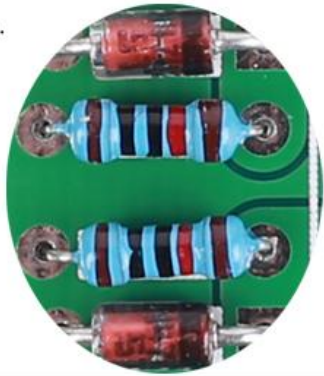
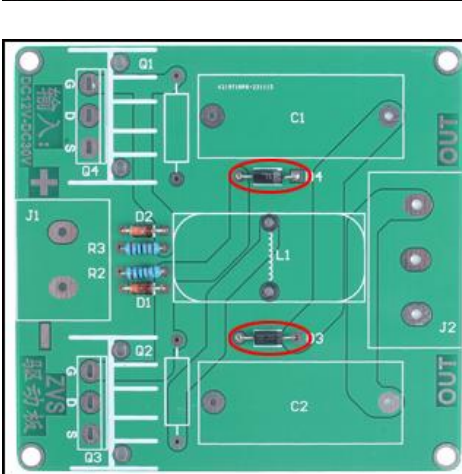
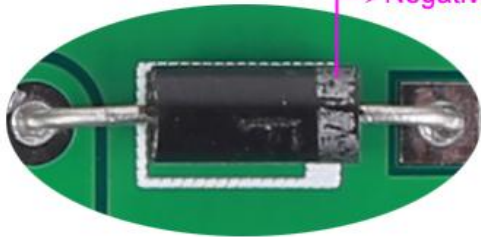
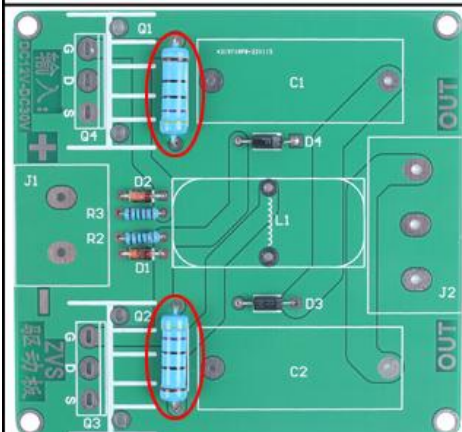
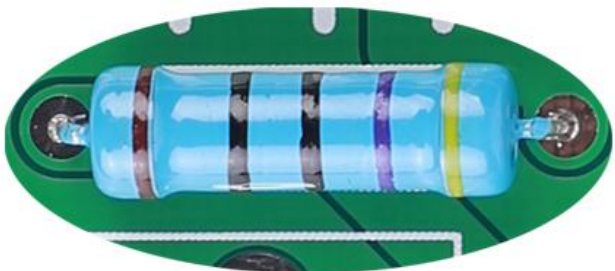
	<p>Step 1: Install 2pcs 12V DO-41 Zener Diode at D1,D2.Pay attention to the installation direction. The negative pole is marked in black.</p>  <p>Negative(Black)</p>
	<p>Step 2: Install 2pcs 10Kohm 1W Metal Film Resistor at R2,R3.</p> 
	<p>Step 3: Install 2pcs 1000V 1A DO-41 Fast Recovery Diode at D3,D4.Pay attention to the installation direction. The negative pole is marked in white.</p>  <p>Negative(White)</p>
	<p>Step 4: Install 2pcs 470ohm 2W Metal Film Resistor at R4,R5.</p> 

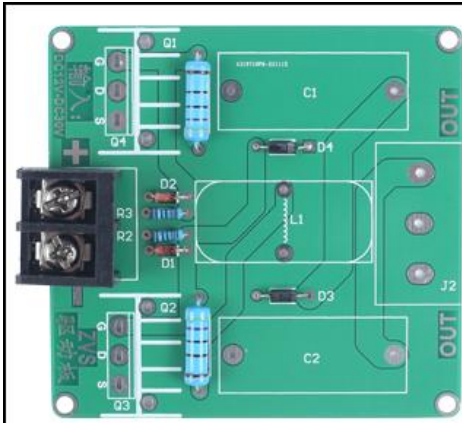

Step 5: Install 1pcs 2Pin HB950 Terminal at J1.

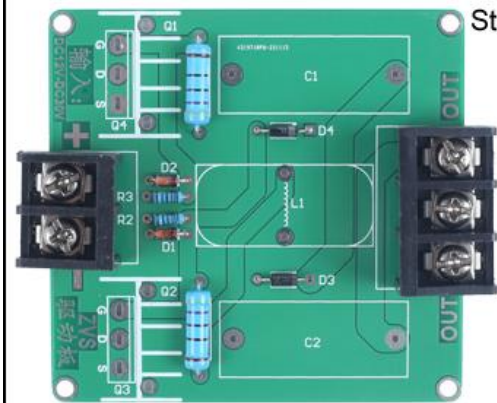

Step 6: Install 1pcs 3Pin HB950 Terminal at J2.

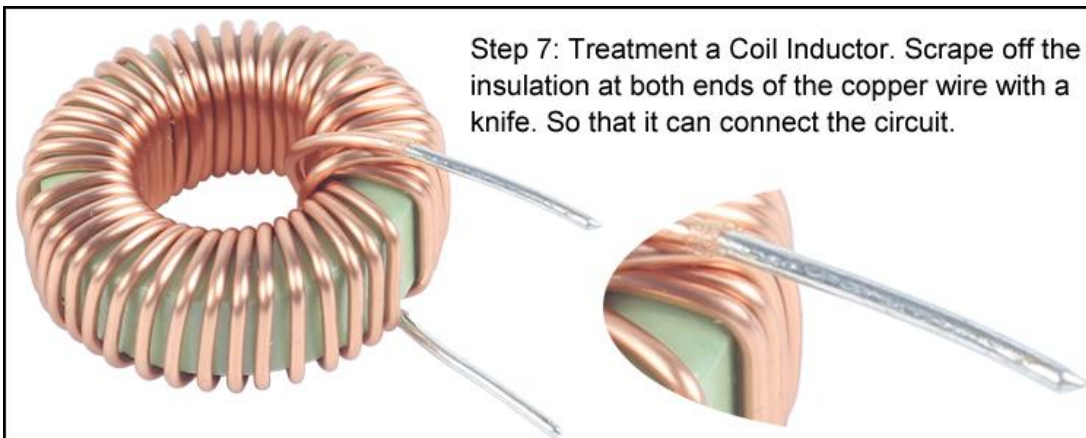

Step 7: Treatment a Coil Inductor. Scrape off the insulation at both ends of the copper wire with a knife. So that it can connect the circuit.

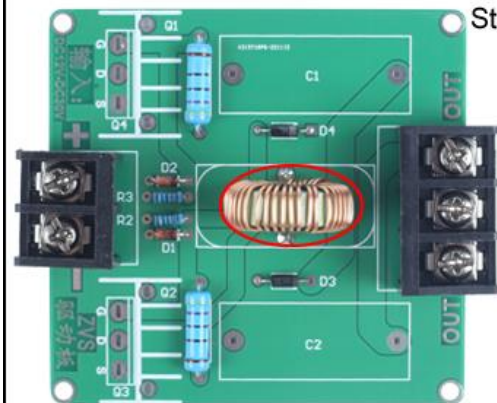

Step 8: Install 1pcs 100uH Coil Inductor at H1.

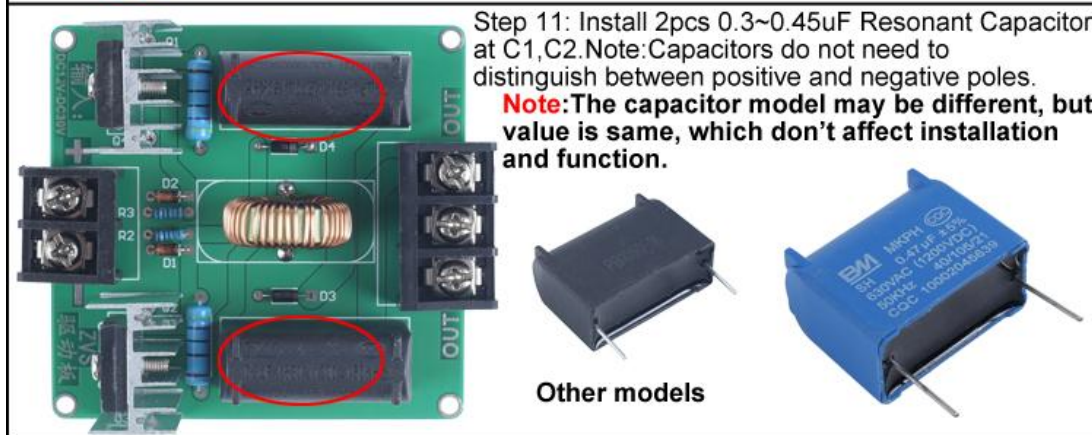
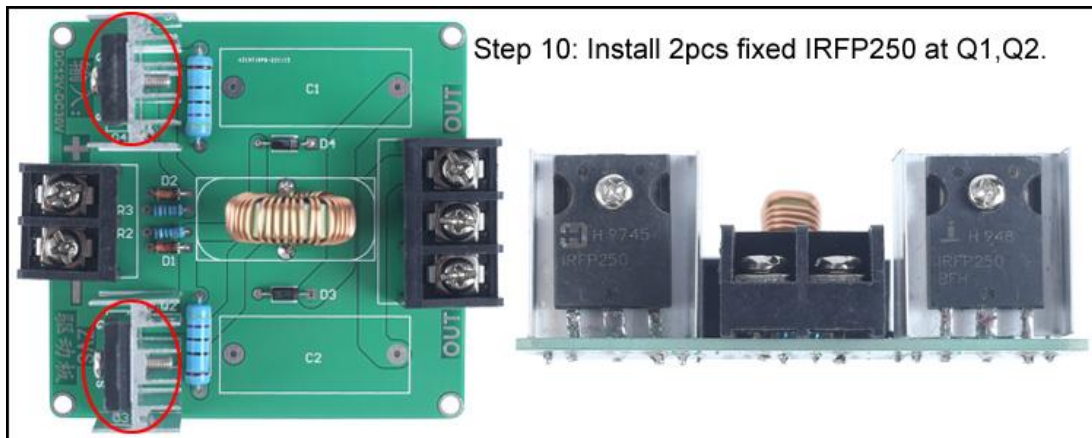
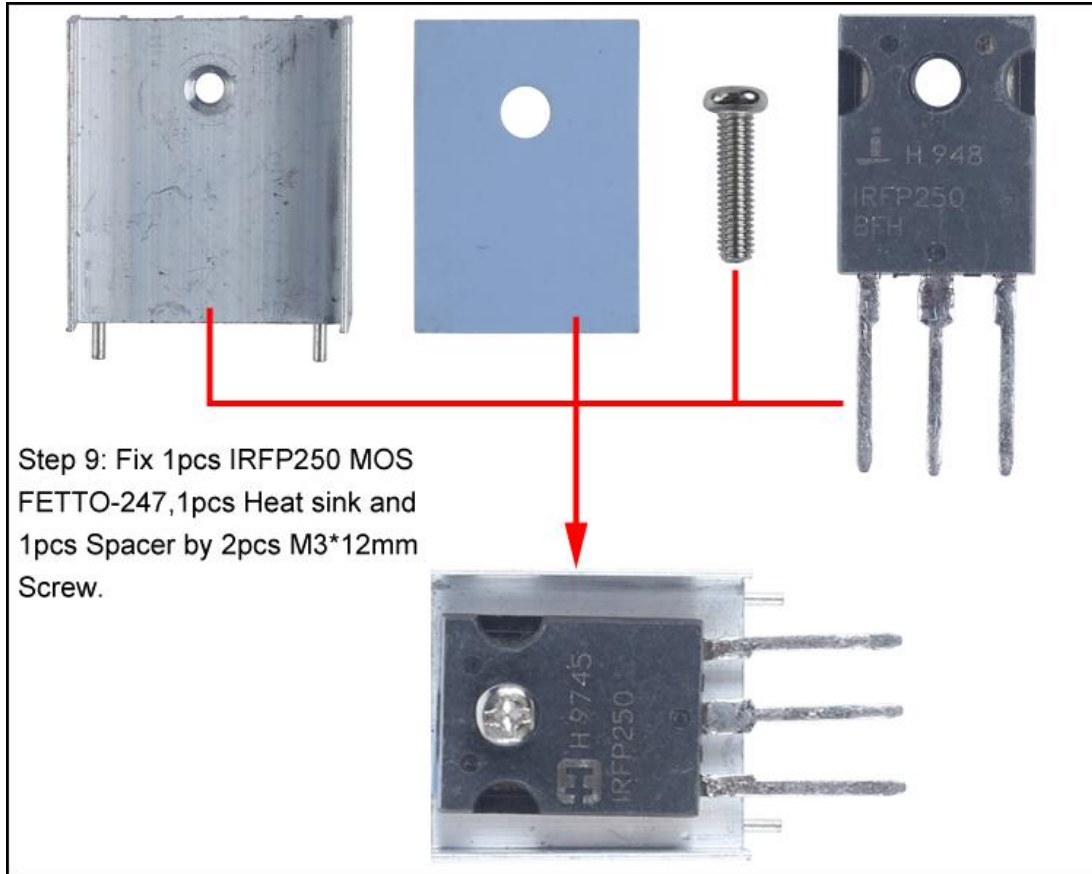

Step 12: Reserved the right pin which marked '-' next red case and remove another pin.

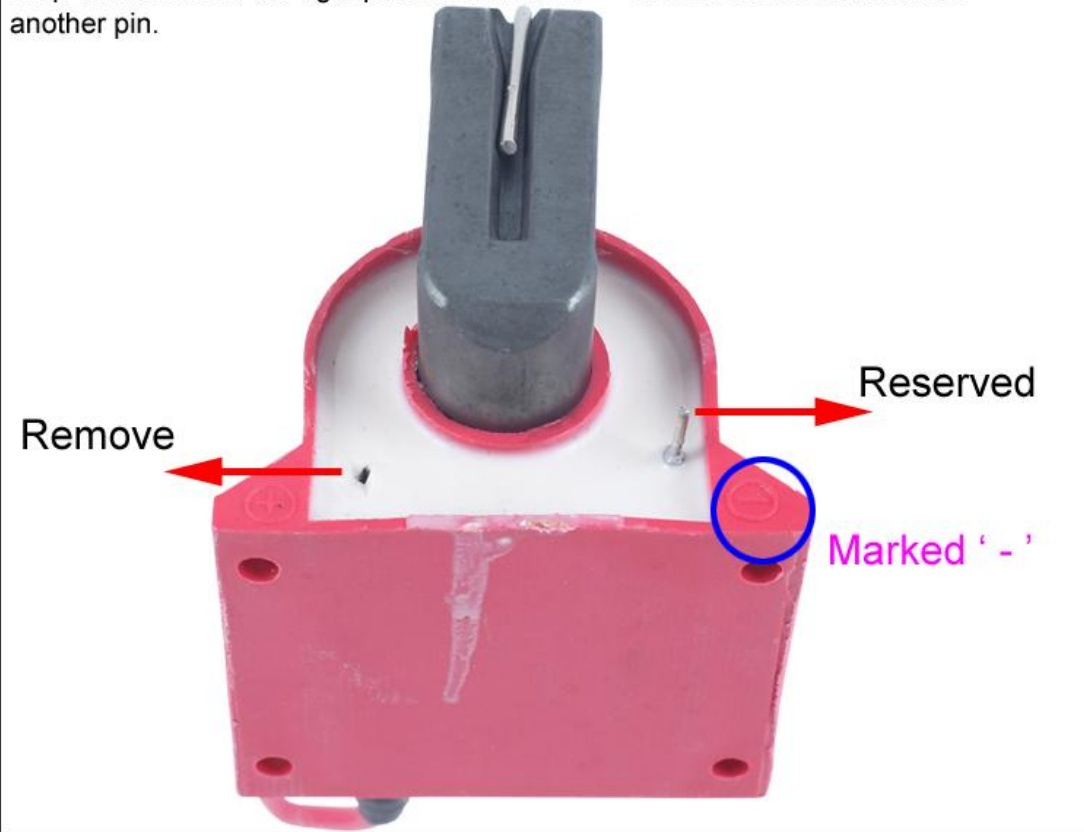

Step 13: Sealing the pin hole by hot melt glue or other insulating glue.
Note: Hot melt glue needs to be prepared by the user in advance.



Step 14: Cut off the red wire and mainly keep about 12cm on Transformer. Then cut and connect about 20cm wire on reserved pin (The wires come from the wires that have just been cut)

Note: user needs to prepare a 12cm wire if the length of the transformer wire is not enough.



Step 15: The 100cm 1.0mm enamelled copper wire is wound on the magnetic core for about 6~10 turns.

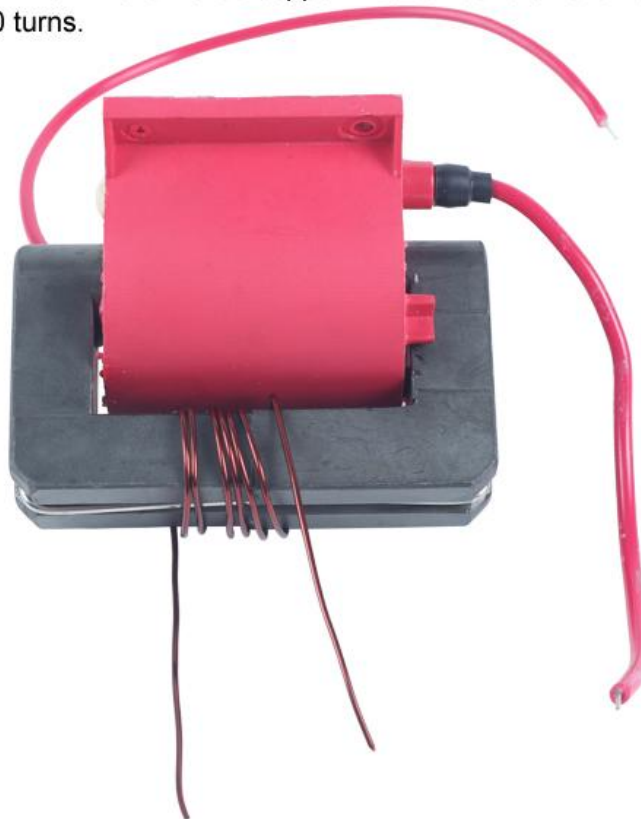

Step 18: Scrape off the insulating layer on the surface of two ends of enameled copper wire.

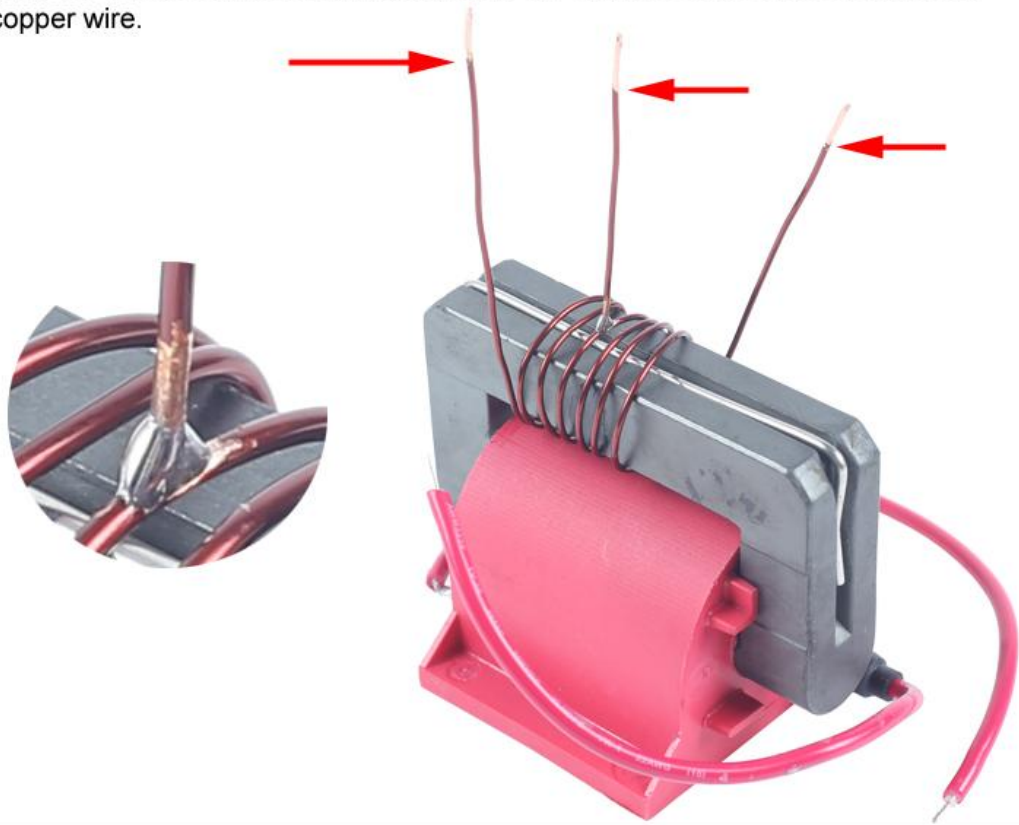

Step 19: Connect the installed transformer to the drive board.

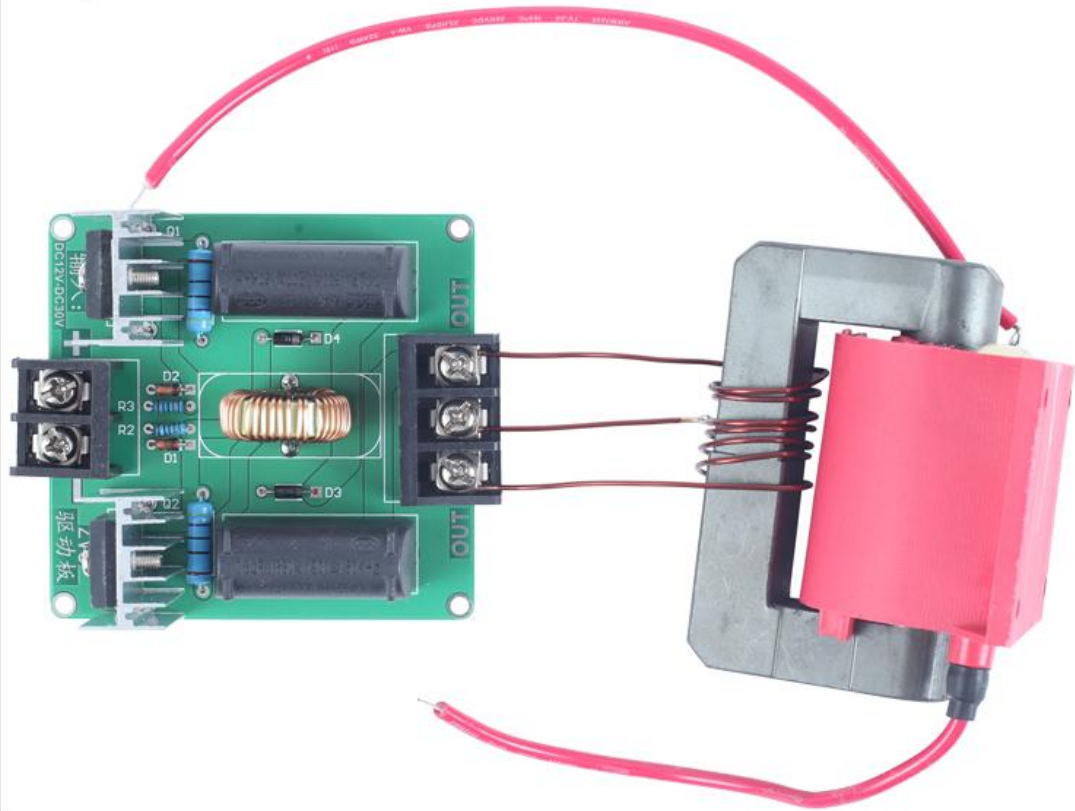

Step 20: Connect DC 12V~36V work power supply to test. Close the two wires within 10mm and then power ON. It is OK if there is an arc. Please pay attention to the safety of operation. It is recommended to use insulating tools.

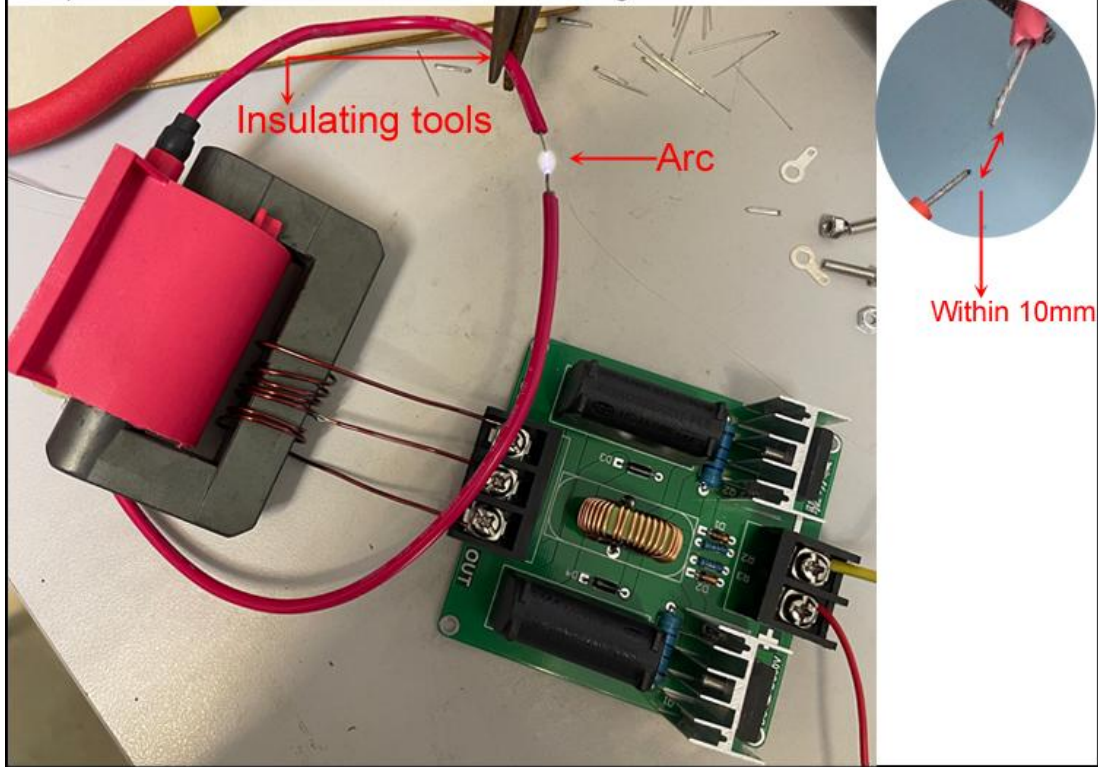

Step 21: Install 10pcs 0.3uF~0.45uF Resonant Capacitor in series. Pay attention pins. **Note:**The capacitor model may be different, but the value is the same, which does not affect the installation and function.



Step 22: Install 10pcs 1Mohm 1/4W Metal Film Resistor on Resonant Capacitor.



Step 23: Handle the transformer and pay attention to the wire connection between transformer and the driver.



Step 24: Fix Driver Module and Transformer 1pcs 150*150*3mm on Wooden Board with hot melt glue. Pay attention to the four corners to keep the spare space for the installation of the column.

Note: Hot melt glue needs to be prepared by the user in advance.

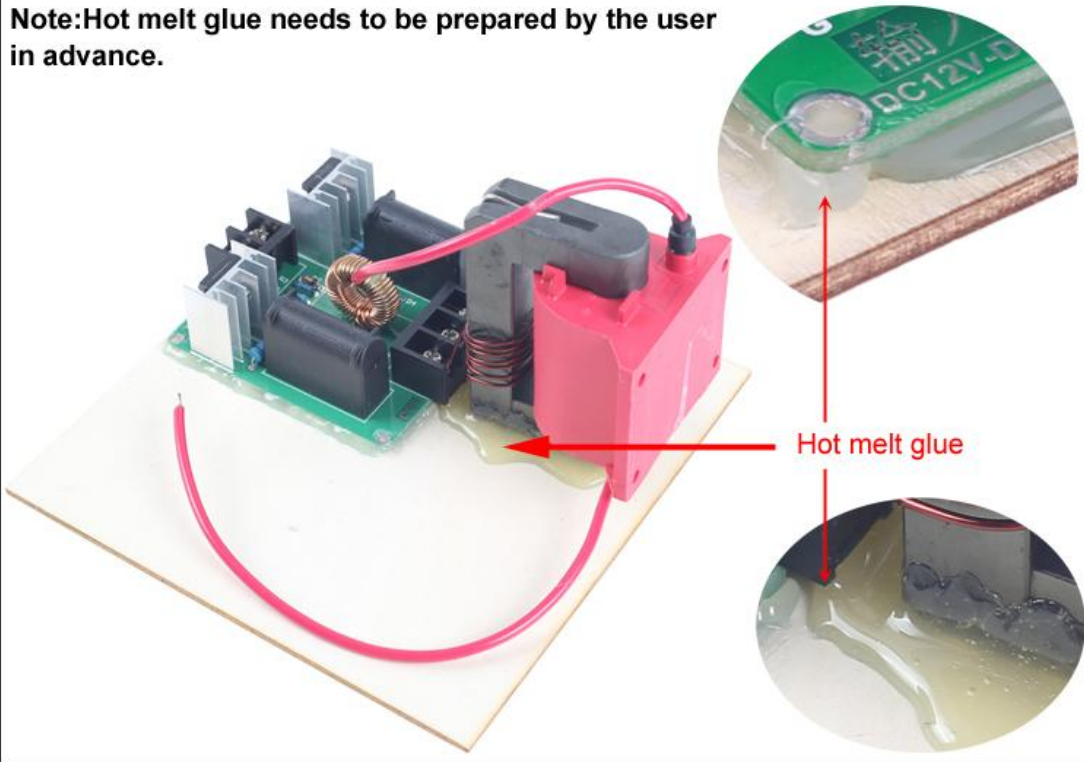

Step 25: Fix Capacitors on Wooden Board with hot melt glue.

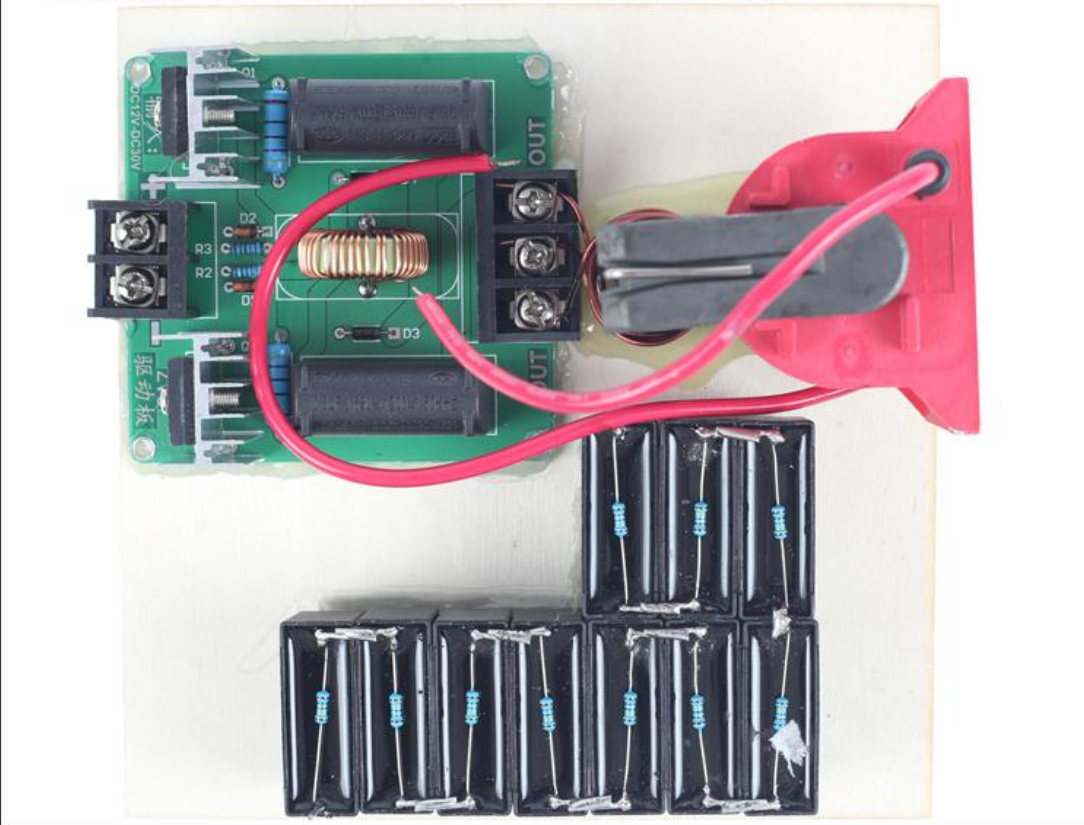

Step 26: Connect the 12cm red wire from Transformer to Resonant Capacitor.

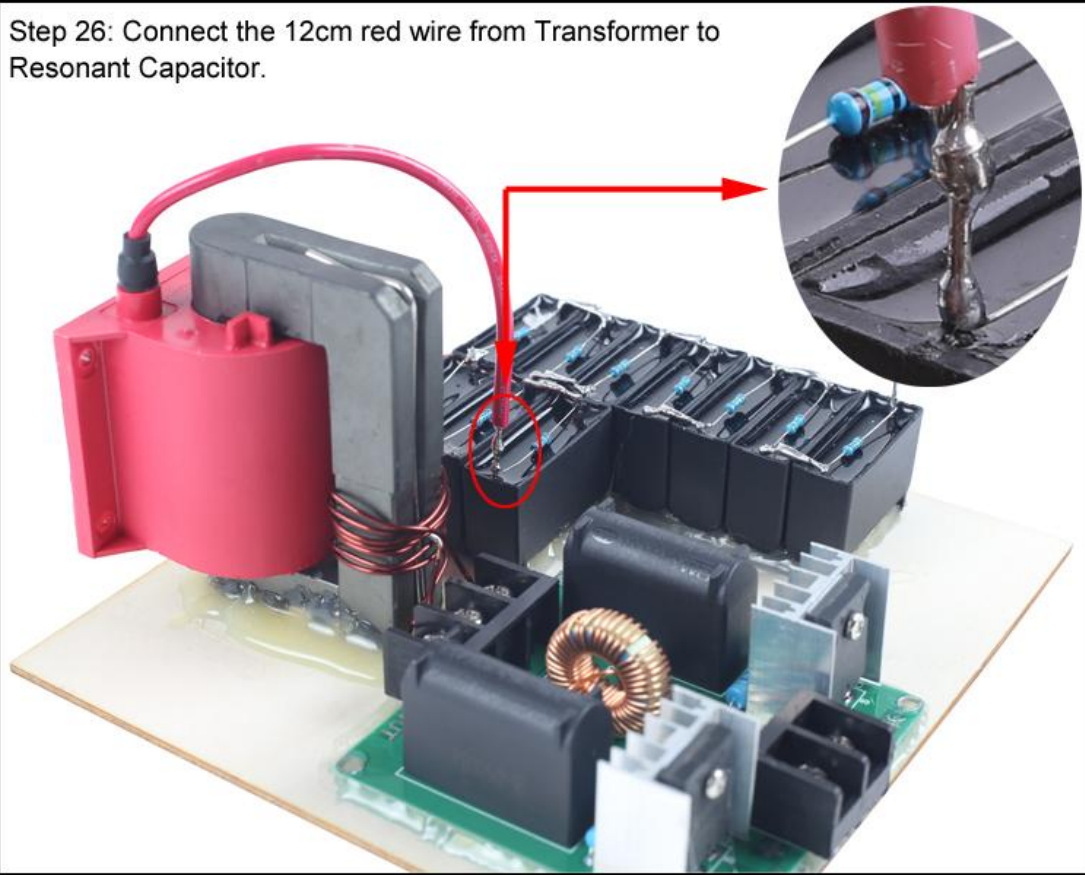

Step 27: Connect the thin wire 20cm wire from the 2nd pin on transformer to another pin of Resonant Capacitor.

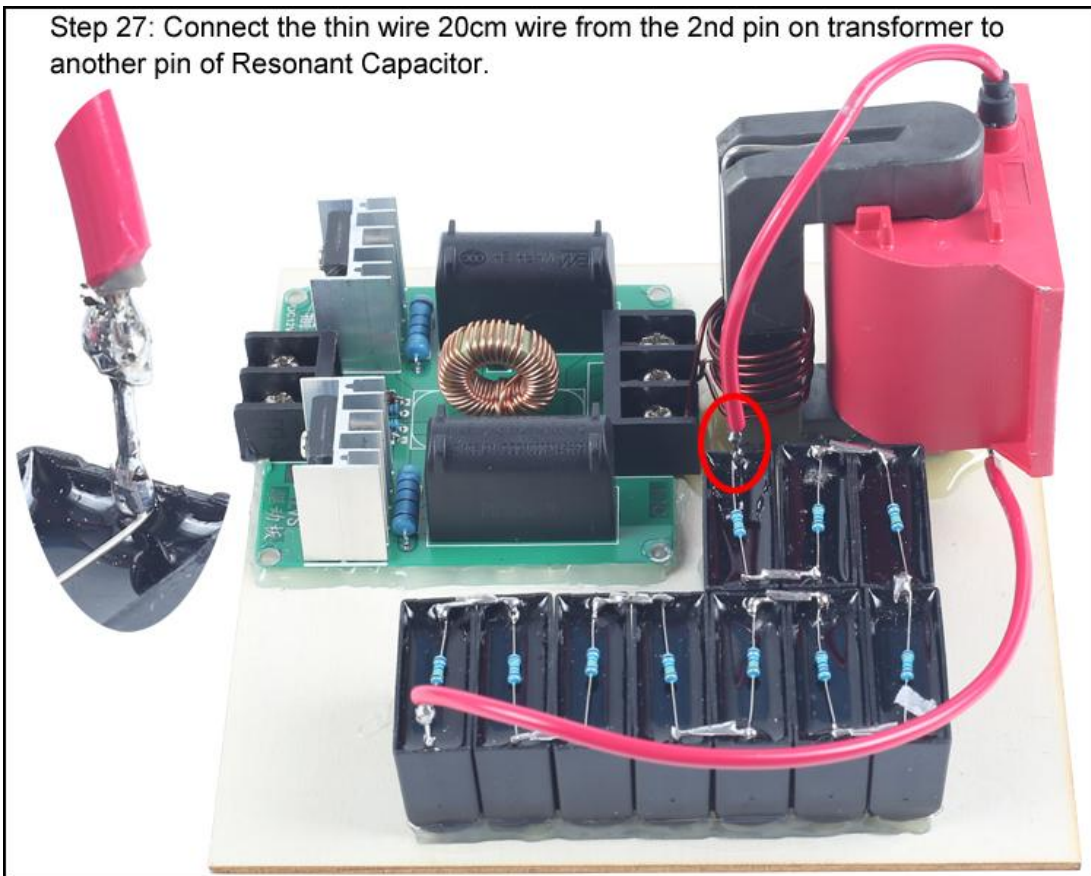

Step 28: Fix 4pcs 10*10*100mm Round Wooden Column on Wooden Board as bracket at four corners by hot melt glue.

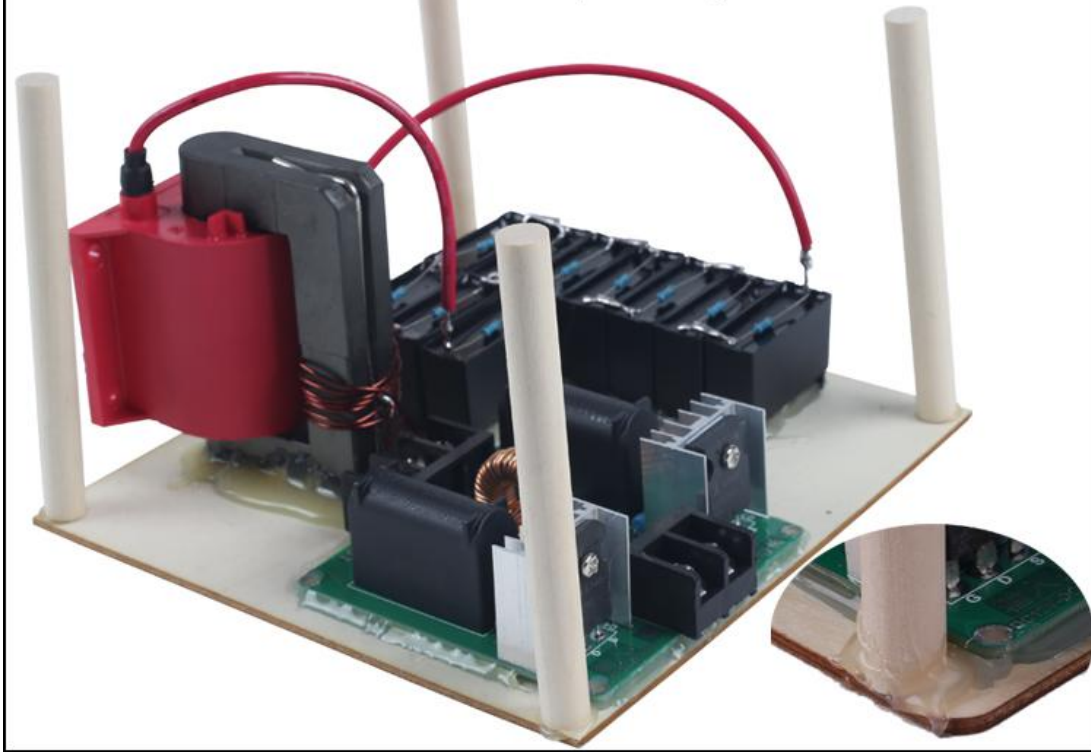

Step 29: Cut 1pcs 50*70*1.2mm universal board into 4pcs according to the mark in the figure. Tips: Along the black line with a knife left to cut cross.

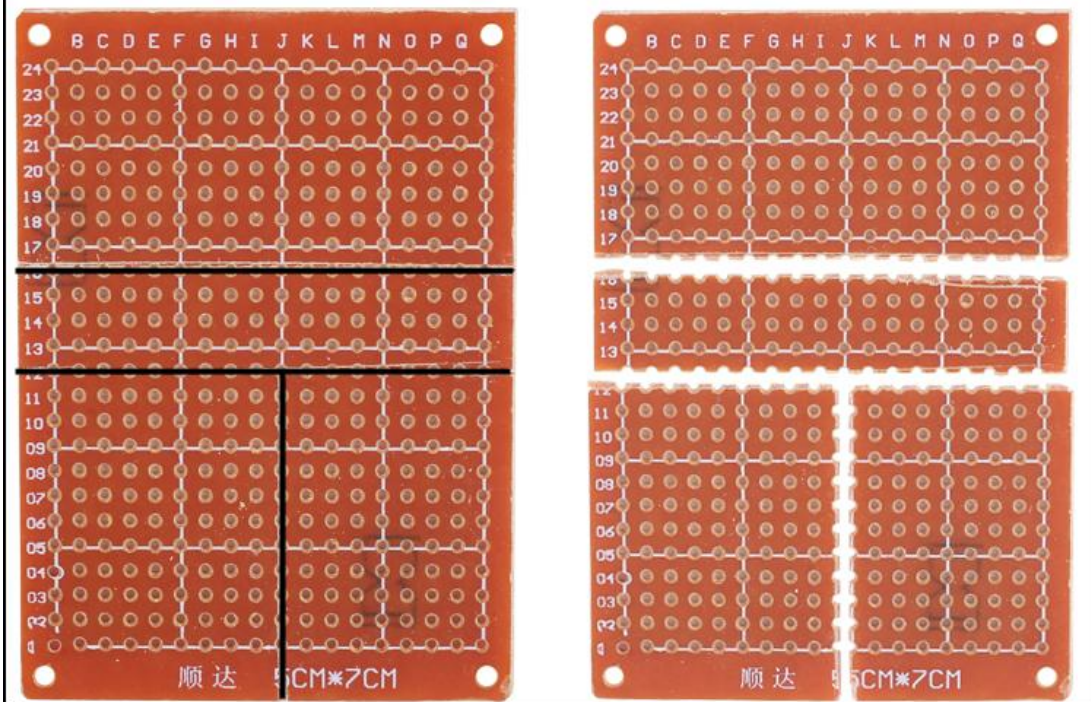

Step 30: Drill two 3mm mounting holes on 2pcs small universal board.

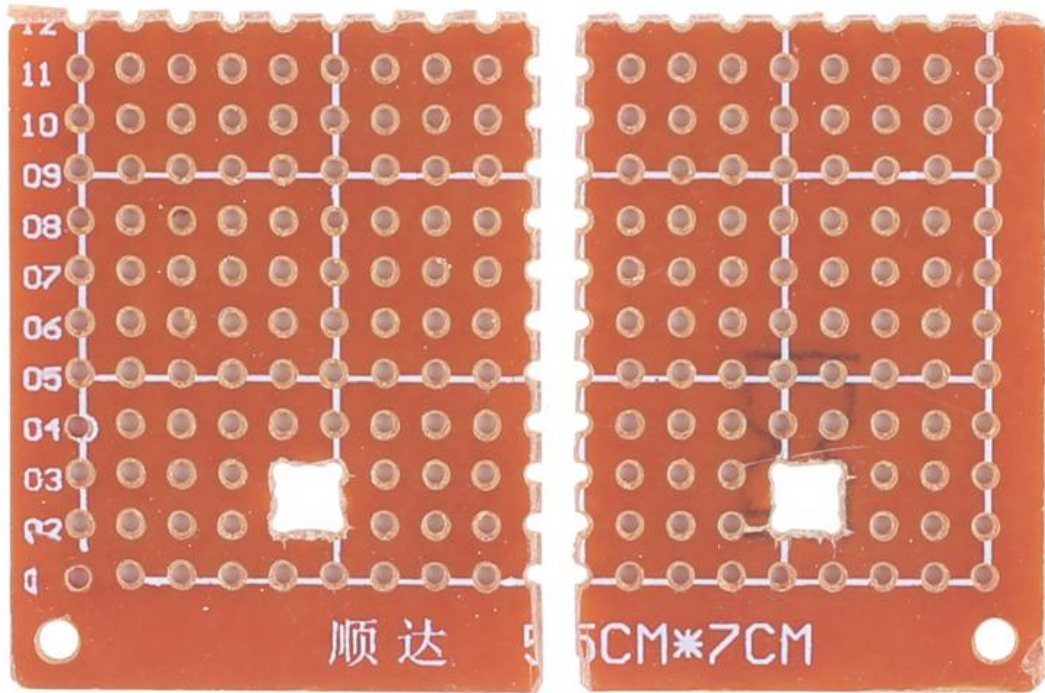

Step 31: Install M3*12mm Screw and M3 Nut and M3 Nut Cap and 2pcs Sheet metal on 2pcs small universal board.

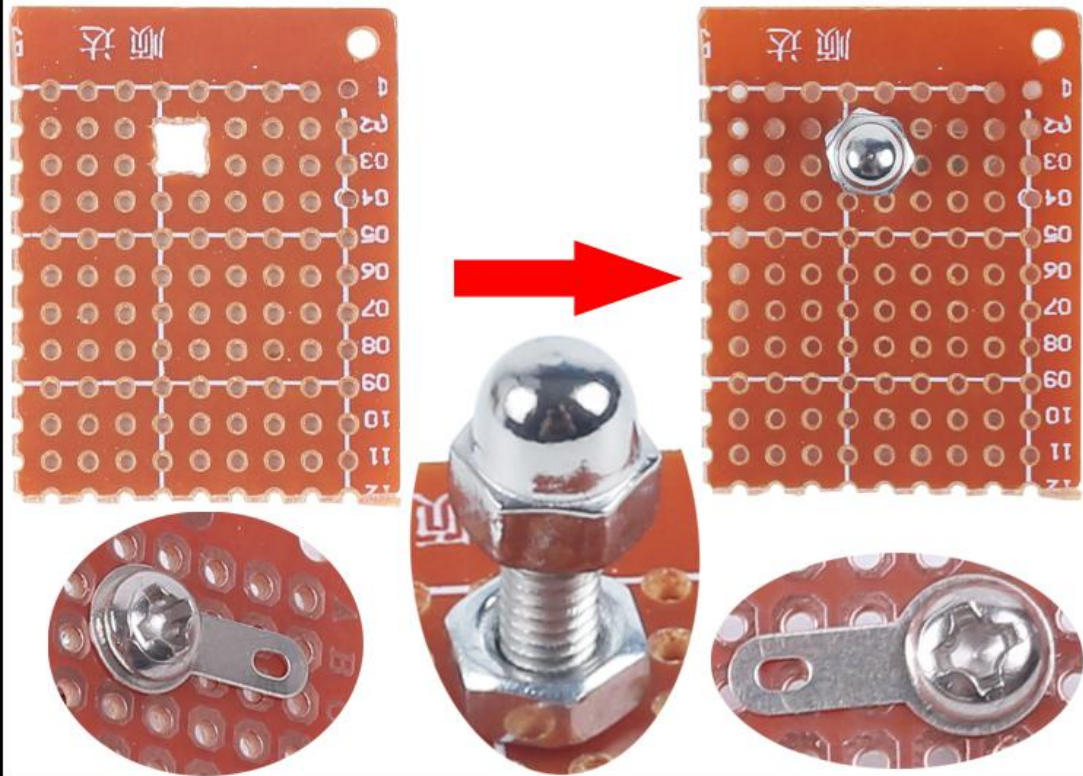

Step 32: Cut the middle universal board about 26cm as limit bracket.

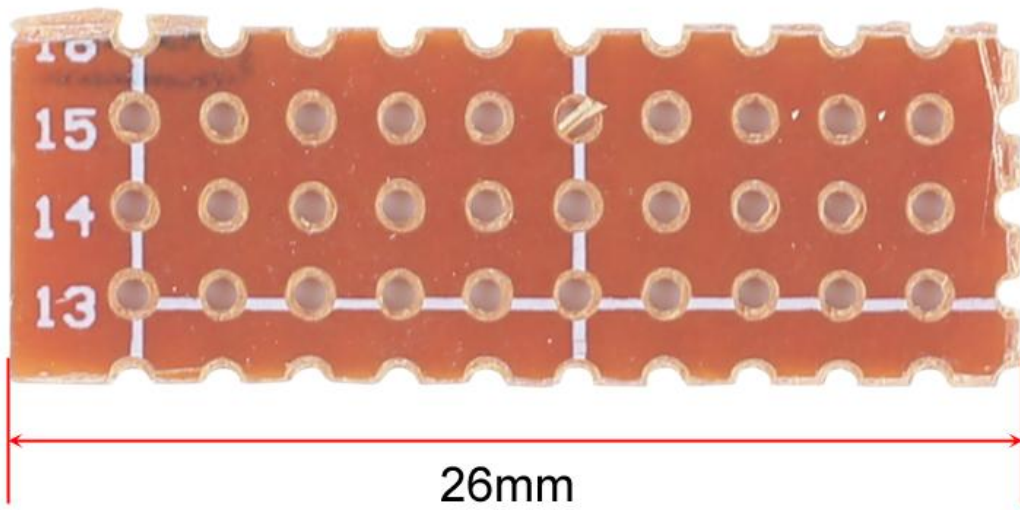

Step 33: Fix 26cm small universal board on the biggest board by hot melt glue as shown.

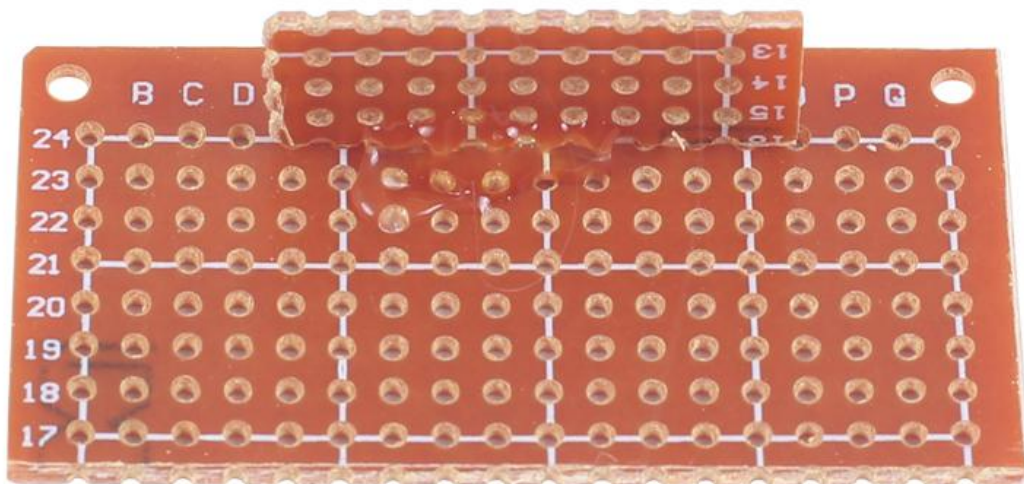

Step 34: Fix another two small universal board by hot melt glue as shown. It's an exciter..

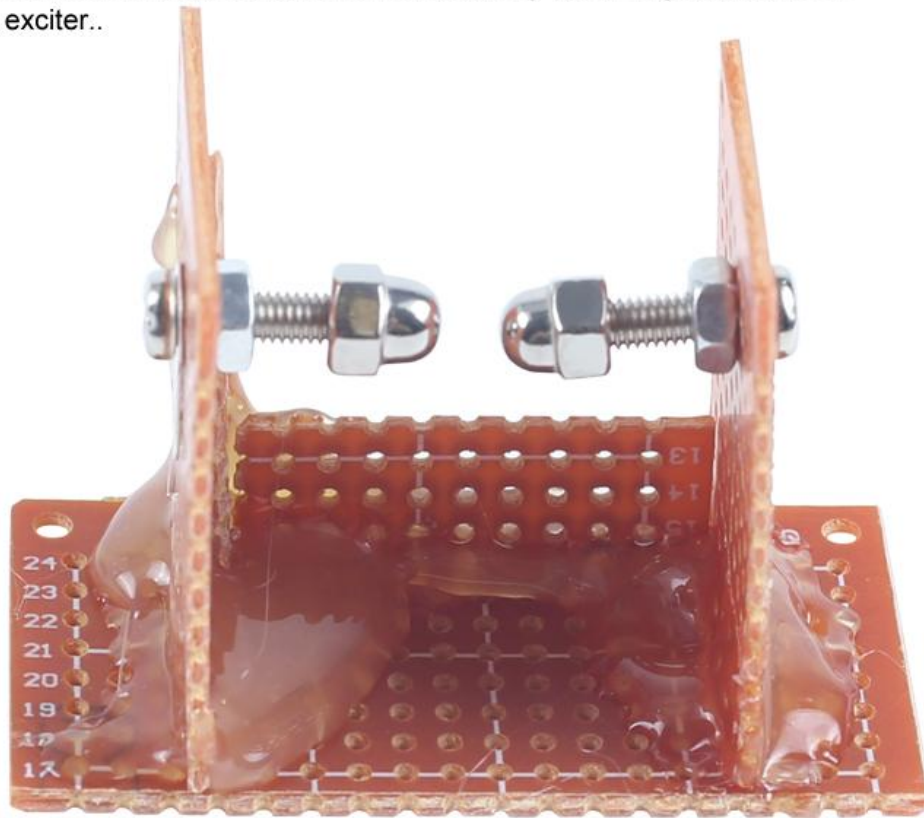

Step 35: Connect 1 pcs about 8cm wire on the left of Sheet metal.

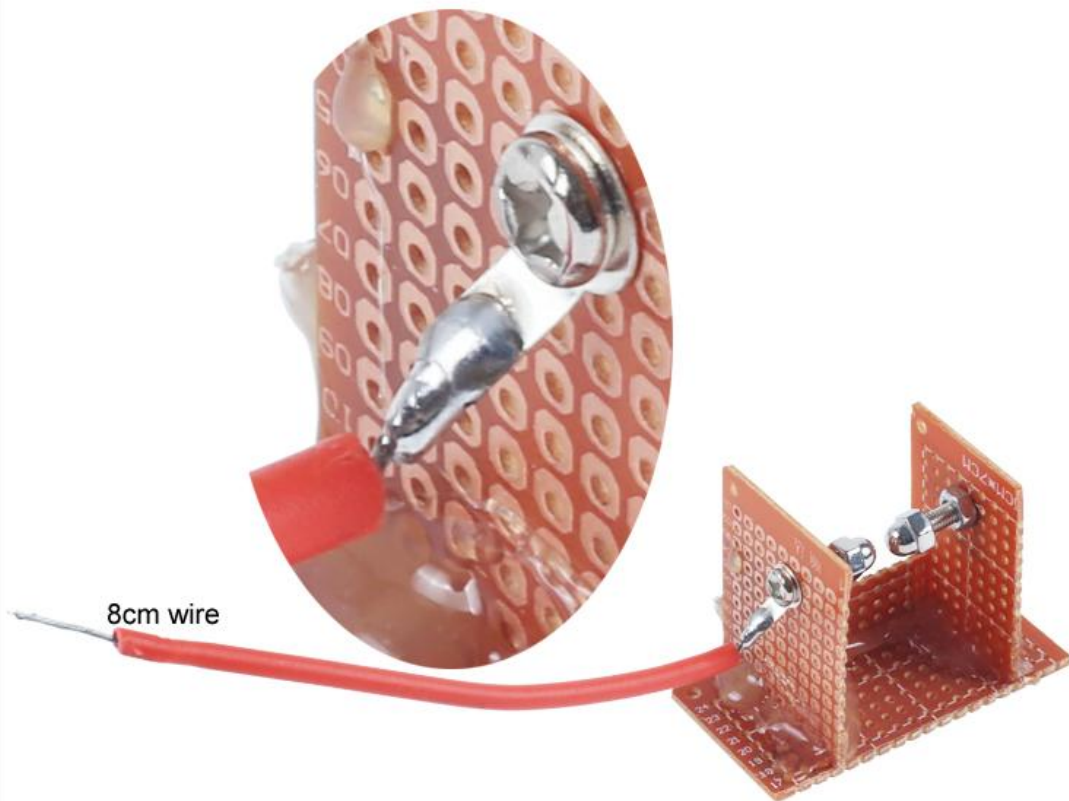

Step 36: Connect 1pcs 50cm 1.0mm enamelled copper wire on another Sheet metal at right. Pay attention to scraping the insulation layer at both ends of the wire.

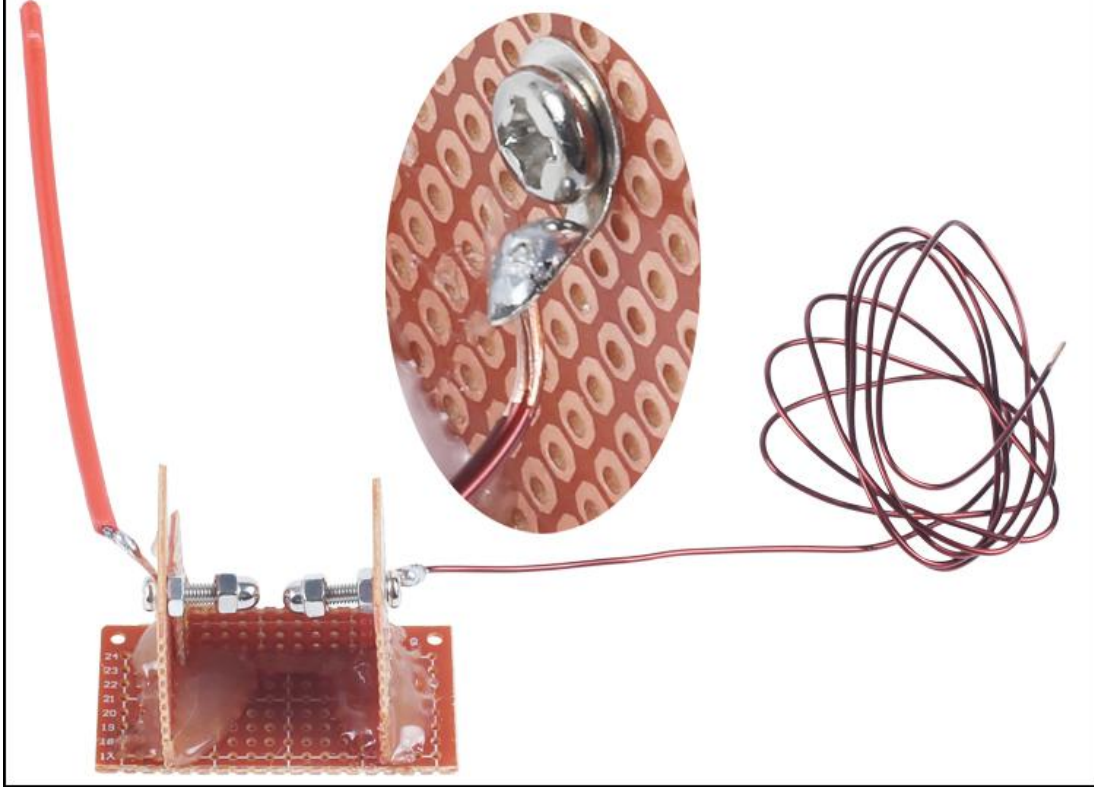

Step 37: Drill 3pcs hole on another 150*150*3mm universal board. The 1st hole in the middle. The other two holes refer to the approximate positions shown in the figure.

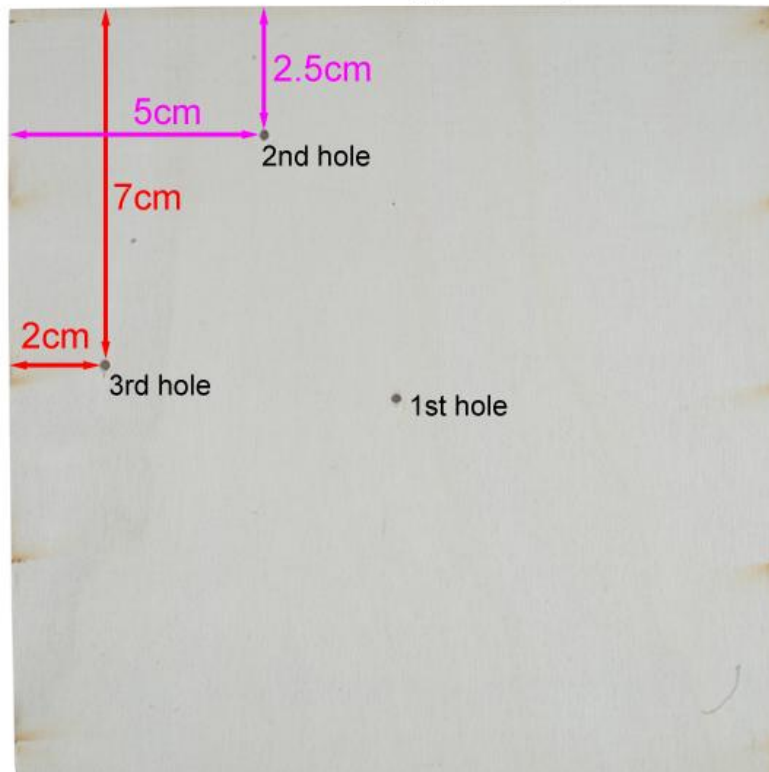

Step 38: Pass the 50cm 1.0mm enamelled copper wire (from exciter) through the 2nd hole.

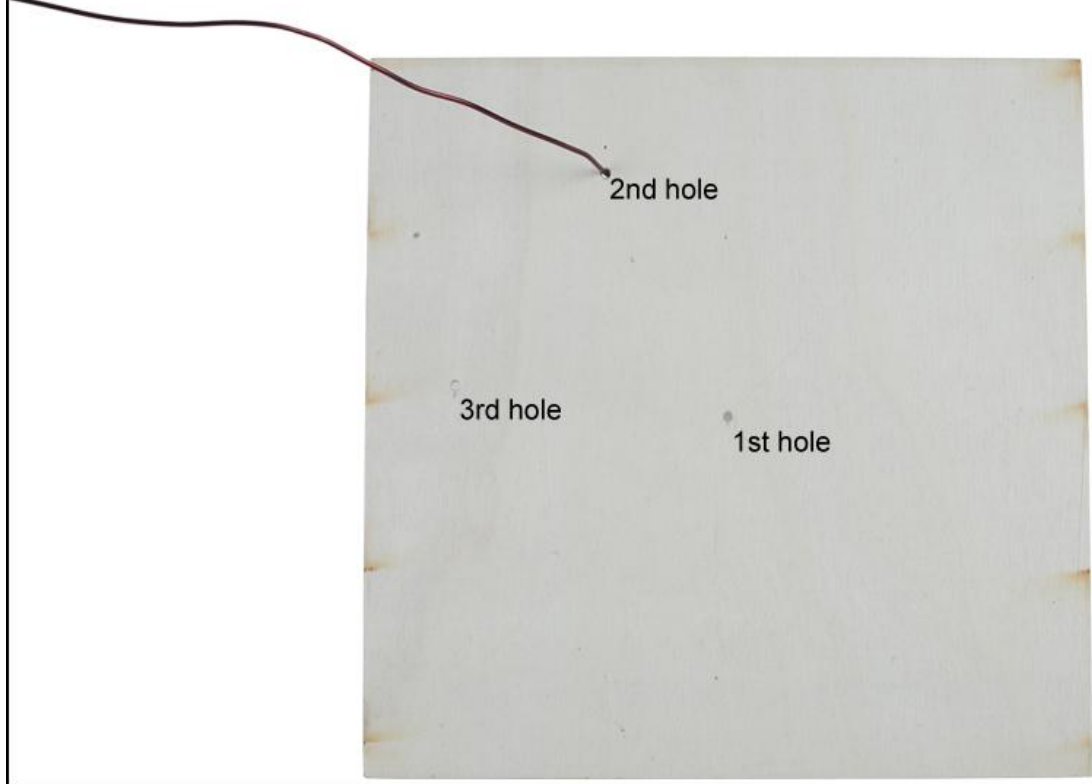

Step 39: Fix exciter on Wooden Board by hot melt glue.

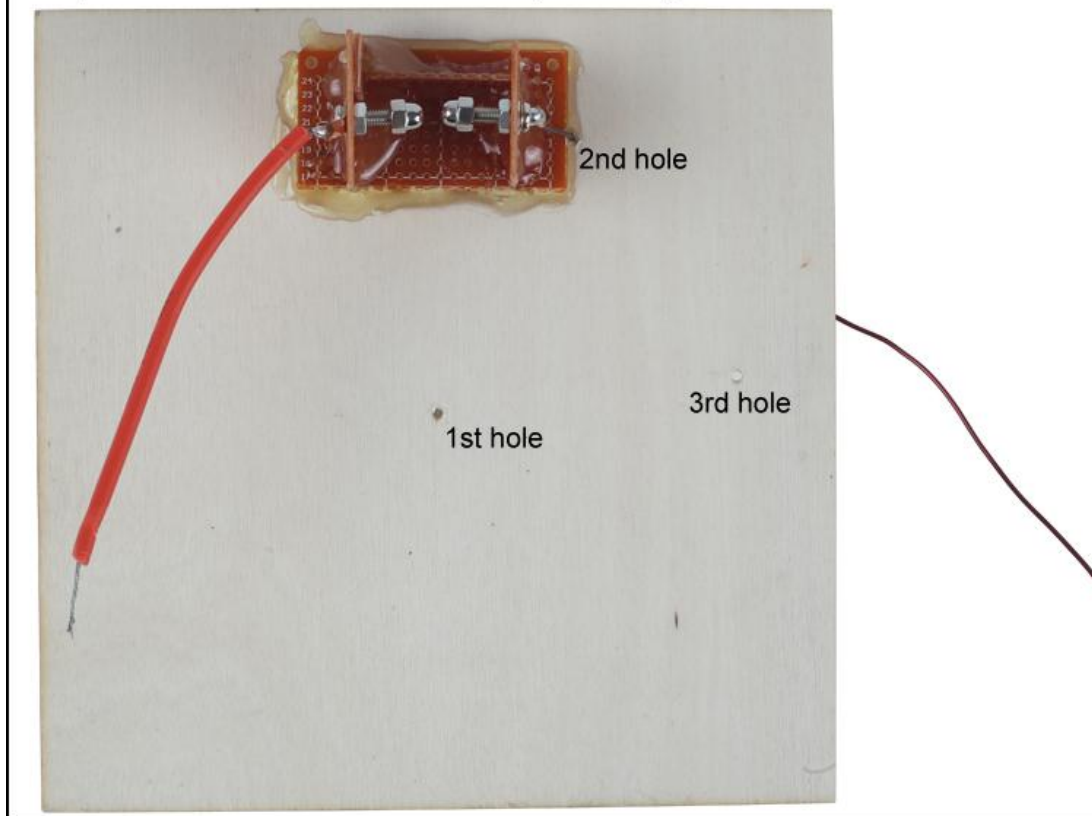

Step 40: Fix 1pcs D82*H70mm Primary Coil Plastic Bracket in the middle of Wooden Board by hot melt glue. Note: there is only one hole inside and other two are outside.

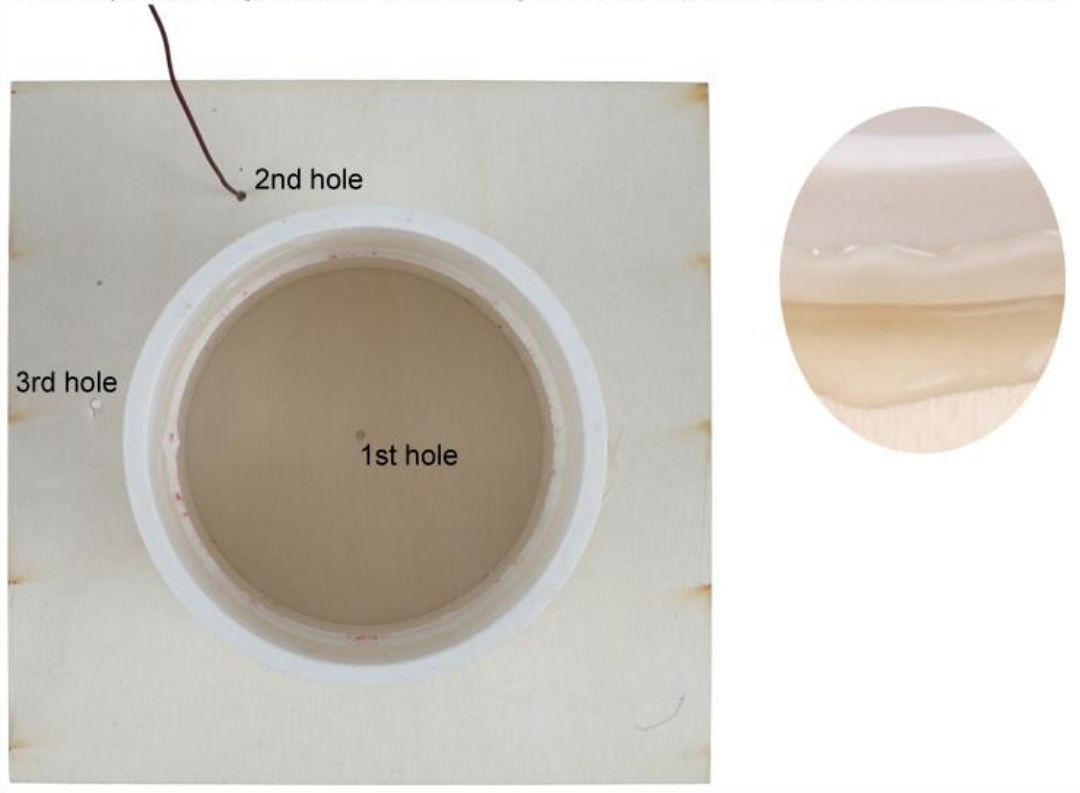

Step 41: Wrap 50cm 1.0mm enamelled copper wire around the D82*H70mm Primary Coil Plastic Bracket as primary coil and fix by adhesive tape. There should be no gap between copper wire and bracket.

Note: You need to prepare insulation tape in advance.

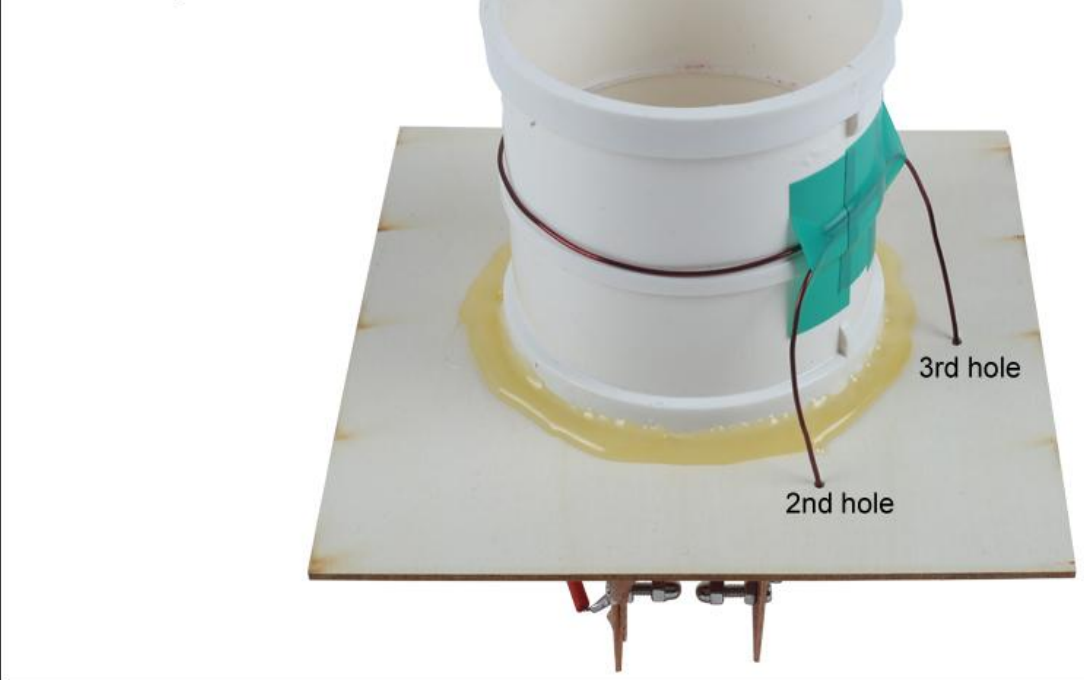

Step 42: Pass the copper wire through the 3rd hole. Pay attention to scrape off the insulating layer on the surface of copper wire.

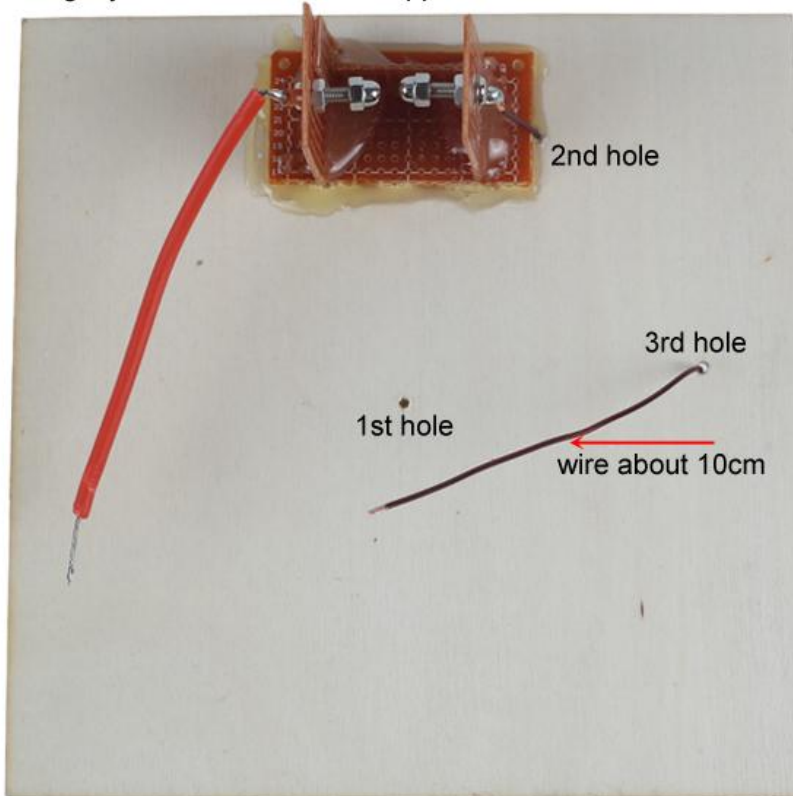

Step 43: Fix Wooden Board on 4pcs 10*10*100mm Round Wooden Column by hot melt glue.



Step 44: Connect 50cm copper wire(from the 3rd hole) to the 12cm red wire on Capacitor.

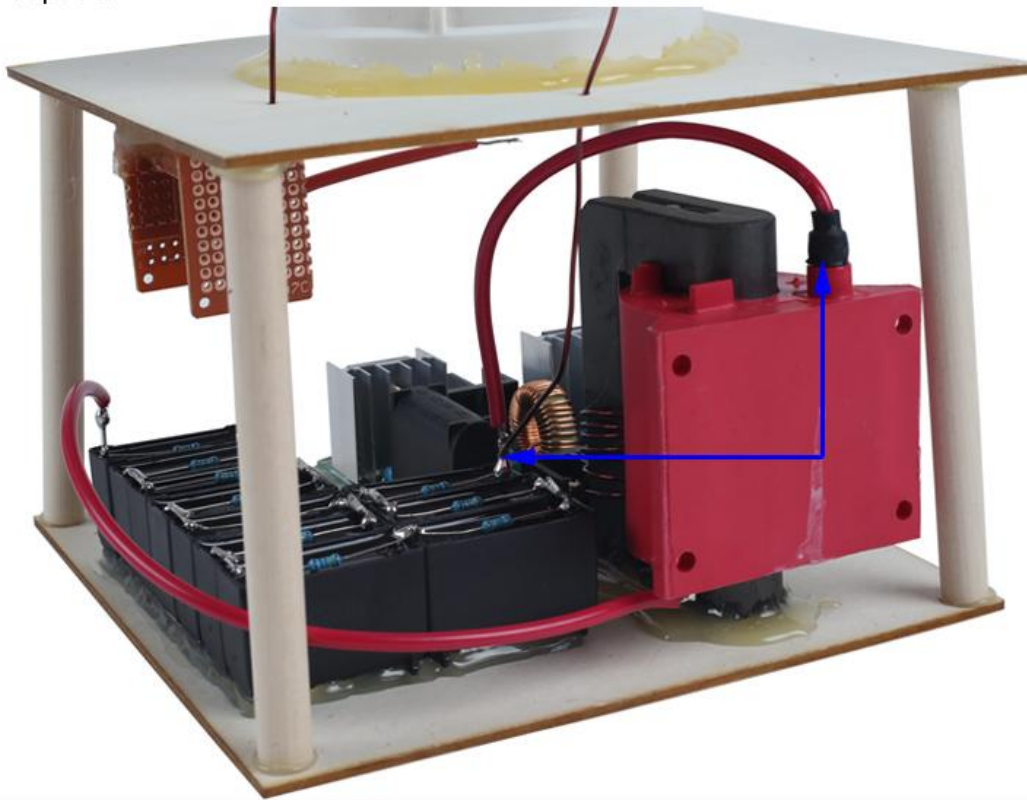

Step 45: Connect 8cm wire(from exciter) to the 20cm wire on transformer on Capacitor

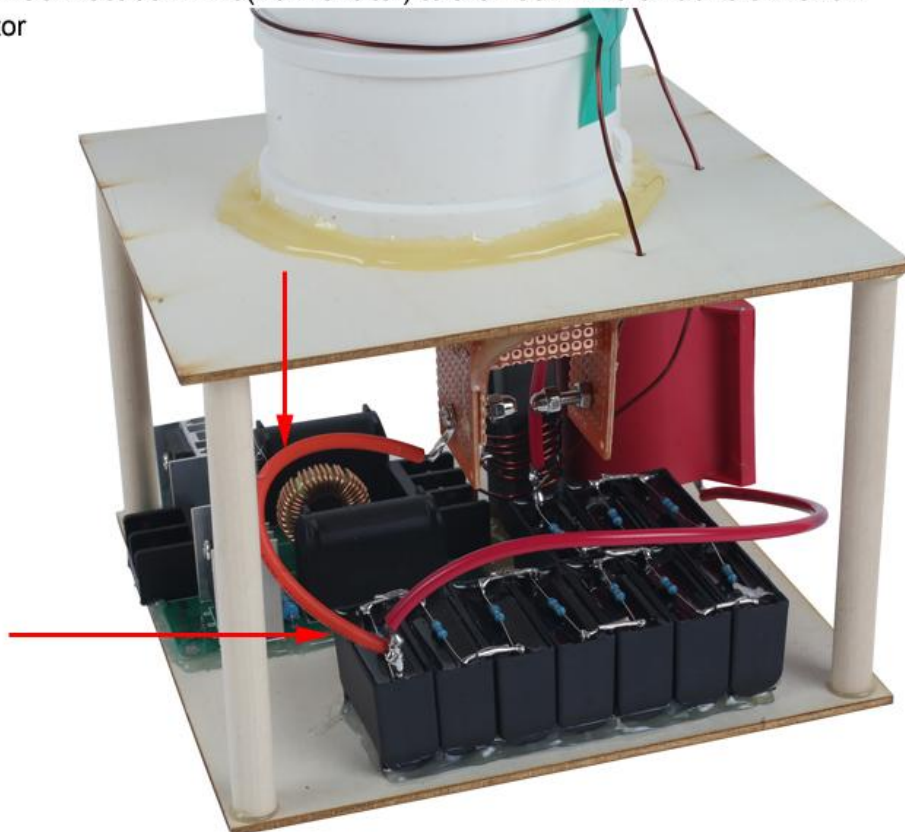

Step 46: Connect about 30cm wire to D40*H247mm Secondary Coil.
Pay attention to scraping the insulation layer at end.

Note: You need to prepare one more than 30cm wire in advance.

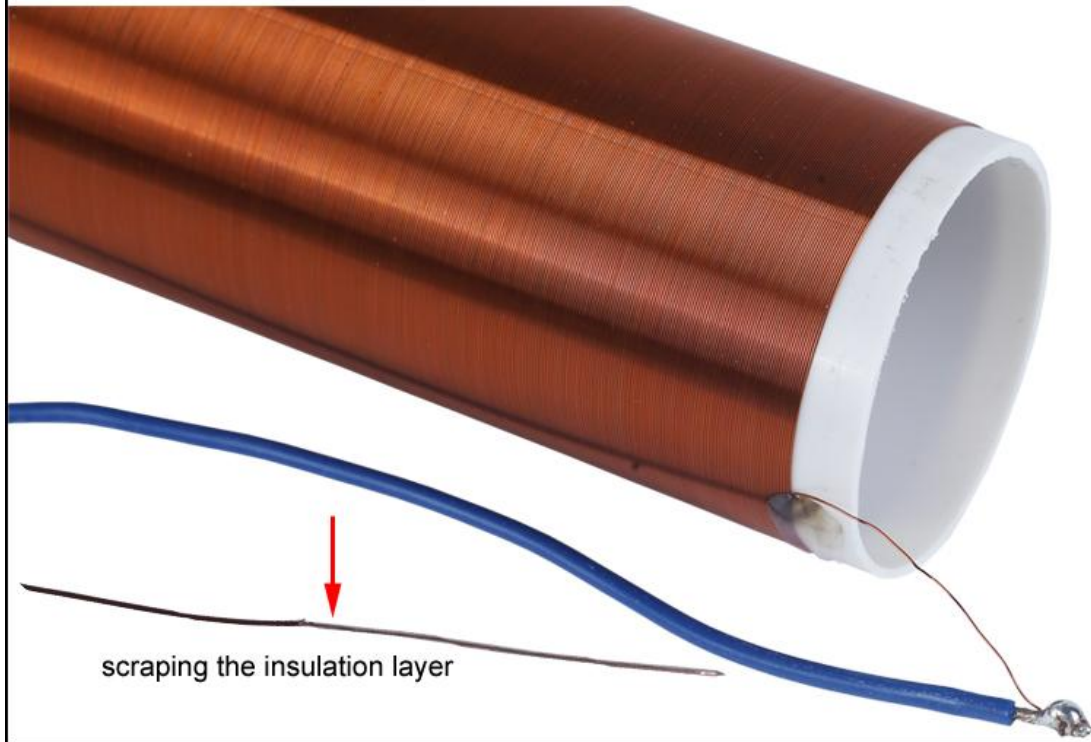

Step 47: Pass the 30cm wire through the 1st hole.

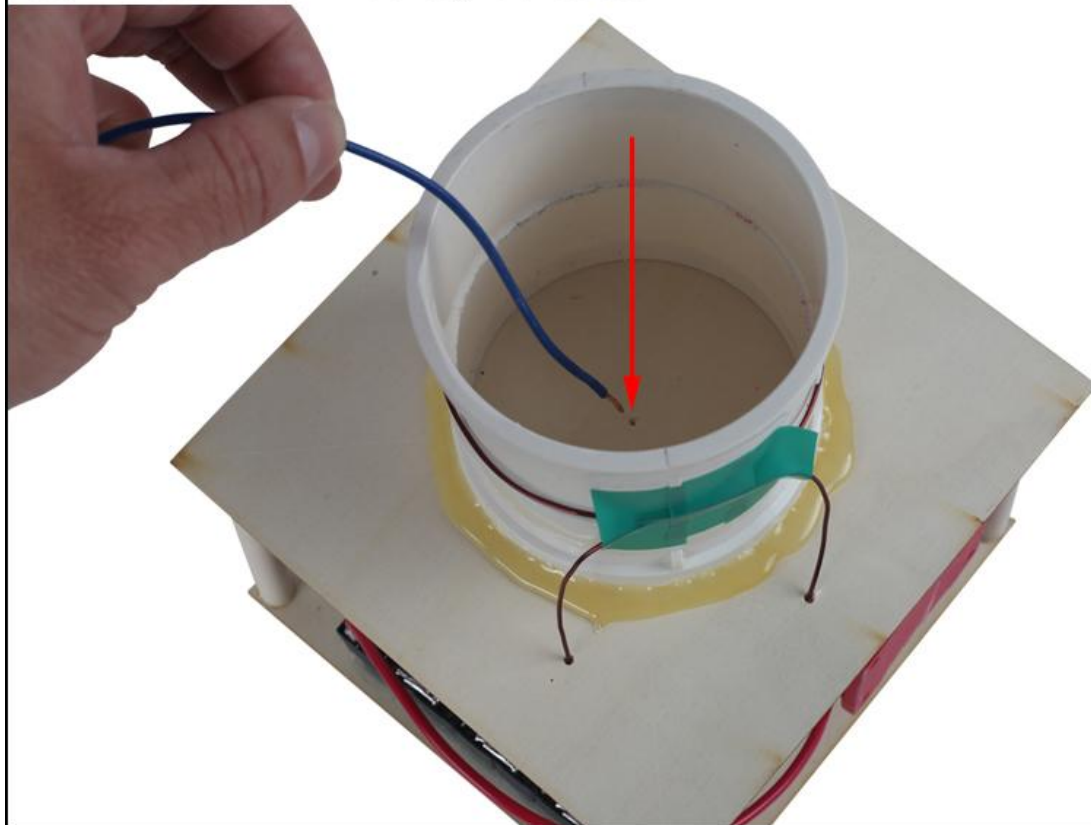

Step 48: Place D40*H247mm Secondary Coil in the middle of D82*H70mm Primary Coil Plastic Bracket.

And place 1pcs 6mm Stainless Steel Metal Ball on D40*H247mm Secondary Coil.



Step 49: Test Note:

- 49.1> . Connect 30cm wire to earth(ground).
- 49.2> . Keep 30cm wire as far away from any wires and components of the product as possible.
- 49.3> . 30cm wire can not connect to household socket or wooden board.
- 49.4> . 30cm wire can connect large metal bodies such as metal doors.
- 49.5> . The secondary coil must be placed in the middle of the primary coil.
- 49.6> . The secondary and primary coils must be level.

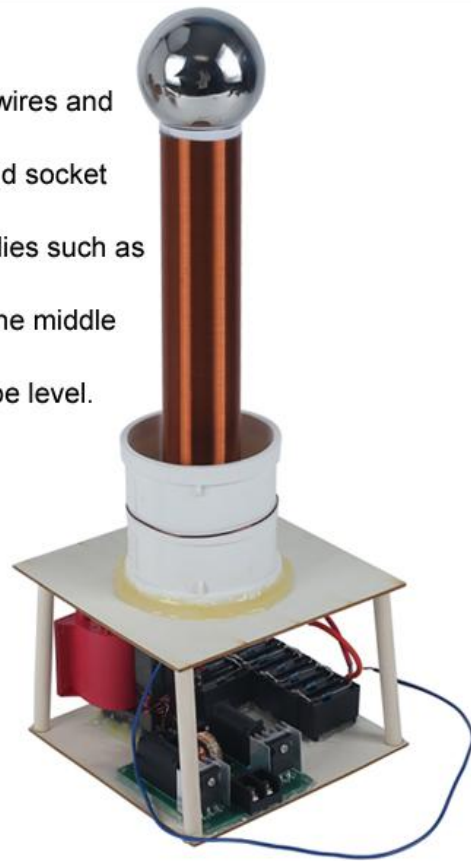

Step 50: Power ON and enjoy.

It is recommended to use **user-prepared** 19V4.7A power supply.

User can adjust the distance between the two screw caps inside of the exciter if the arc is not satisfied.

The distance between screw caps is generally 1~2mm.

Note: The power must be cut off before adjustment.

